

LINE TABLE

LINE	LENGTH	BEARING
L1	2002.50	N89°35'31"W
L2	10.00	N01°14'21"E
L3	NOT USED	NOT USED
L4	NOT USED	NOT USED
L5	NOT USED	NOT USED
L6	NOT USED	NOT USED
L7	9.90	N01°34'25"E
L8	NOT USED	NOT USED
L9	NOT USED	NOT USED
L10	211.27	S88°55'31"E
L11	11.47	S92°02'24"E
L12	225.00	S88°35'31"E
L13	119.19	S01°24'23"W
L14	NOT USED	NOT USED
L15	59.43	N01°52'25"E
L16	75.75	S50°39'04"W
L17	28.89	S07°53'17"W
L18	209.44	S86°34'53"W
L19	63.88	S65°15'54"W
L20	63.88	S65°15'54"W
L21	136.95	S76°25'57"W
L22	241.61	S42°14'33"W
L23	192.88	S11°11'44"W
L24	7.72	S07°53'17"W
L25	143.53	S86°34'53"W
L26	45.77	S66°33'50"W
L27	45.77	S66°33'50"W
L28	143.48	S66°23'16"W
L29	NOT USED	NOT USED
L30	34.89	S88°15'09"W
L31	18.86	S33°14'33"W
L32	18.86	S33°14'33"W
L33	114.06	S52°15'31"W
L34	110.75	S47°29'59"W
L35	216.73	S67°35'57"W
L36	207.66	S81°40'34"W
L37	348.78	S78°21'17"W
L38	107.98	S78°21'17"W
L39	107.98	S71°45'07"W
L40	68.53	S56°13'10"W
L41	NOT USED	NOT USED
L42	NOT USED	NOT USED
L43	NOT USED	NOT USED
L44	75.42	N01°43'59"W
L45	NOT USED	NOT USED
L46	NOT USED	NOT USED
L47	NOT USED	NOT USED
L48	NOT USED	NOT USED
L49	NOT USED	NOT USED
L50	NOT USED	NOT USED
L51	NOT USED	S01°22'29"W
L52	NOT USED	S01°22'29"W
L53	NOT USED	N01°16'57"E
L54	2002.40	S89°35'31"E

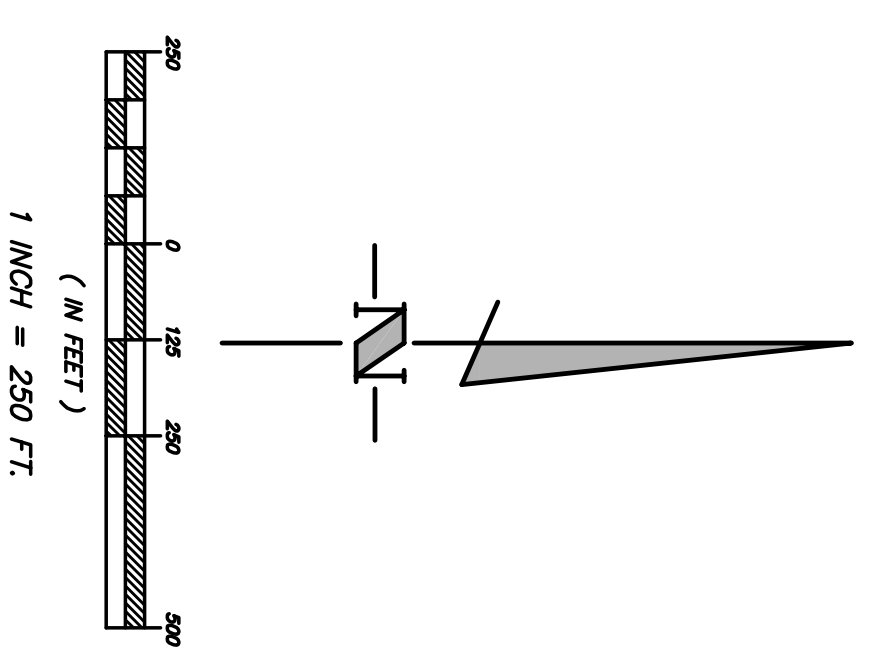

Improvement Phasing Matrix

	Phase I	Phase II	Phase III	Phase IV	Phase V
Tank Farm Road					
Reduction of tank farm road right-of-way through entire site	X				
Installation of traffic signal at Tank Farm Road and Santa Fe Road Intersection	X				
Extension of at-grade culvert where Tank Farm Road crosses Acacia Creek	X	X			
Construction of multi use path along south side of Tank Farm Road	X	X	X		
Construction of Tank Farm Road surface and full frontage improvements	X	X	X	X	
Combination and relocation of overhead utilities running east to west across site to one underground utility trench in Tank Farm Road	X	X	X	X	
Construction of curb inlets to collect roadway runoff along Tank Farm Road	X	X	X	X	
Construction of drainage swales to collect surface runoff from development north of Tank Farm Road to Road "B"	X	X	X	X	
Reduction and replacement of drainage culvert where the riparian corridor crosses Tank Farm Road	X	X	X	X	
Installation of reclaimed water line in Tank Farm Road	X	X	X	X	
Installation of domestic water line in Tank Farm Road	X	X	X	X	
Construction of drainage swales to channel storm water from the outlet point north west of Road "B" to detention areas in the open space	X	X	X	X	
North Santa Fe Road					
Construction of North Santa Fe Road interim width for easerly frontage improvements	X				
Completion of North Santa Fe Road remaining frontage improvements	X	X			
Construction of sewer line in Santa Fe Road	X	X			
Installation of reclaimed water line in Santa Fe Road	X	X			
Installation of domestic water line in Santa Fe Road	X	X			
Construction of storm drain in Santa Fe Road	X	X			
Construction of curb inlets to collect surface water from Santa Fe Road and development northeast	X	X			
South Santa Fe Road					
Construction of South Santa Fe Road surface and full frontage improvements	X				
Installation of large scale culvert at East Fork of San Luis Creek	X				
Construction of sewer line in Santa Fe Road	X				
Installation of reclaimed water line in Santa Fe Road	X				
Installation of domestic water line in Santa Fe Road	X				
Extension of services to individual lots south of Tank Farm Road	X				
Construction of drainage basin and swale to collect surface runoff south of Tank Farm Road	X				
Road "A"					
Construction of Road "A" surface and full frontage improvements from North Santa Fe Road to project boundary	X				
Road "B"					
Construction of Road "B" surface and full frontage improvements from North Santa Fe Road to the beginning of the knuckle	X				
Construction of Road "B" surface and full frontage improvements from Tank Farm Road to the knuckle	X				
Construction of storm drain in Road "B"	X				
Installation of curb inlets draining to underground storm drain system	X				
Construction of overhead drainage swale west from knuckle across recreation lot	X				
Installation of sewer in Road "B" from clean out at Santa Fe Road to existing sewer main on Tank Farm Road	X				
Installation of reclaimed water line in Road "B"	X				
Installation of domestic water line in Road "B"	X				
Extension of services to individual lots	X				
Extension of utilities into future phases if necessary	X				

Boundary and Phasing Plan
San Luis Obispo Tank Farm

Tract 2981, City of San Luis Obispo
 June 18, 2008 revised Nov 19, 2008 SHEET: 2 of 8

C-2